

FLO01BIN

PVC

Flessibile rinforzato bianco/azzurro.

Reinforced white/bluish flexible hose.

Flexible renforcé blanc/bleu.

120-01	€	5,80
150-01	€	6,30
200-01	€	6,80
120-BOX	€	6,30
150-BOX	€	6,80
200-BOX	€	7,30

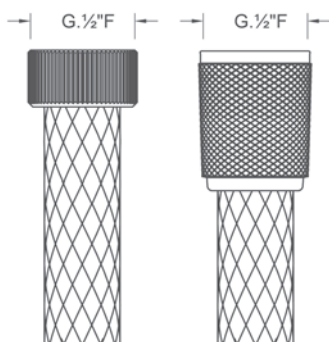

FLO01NEN

PVC

Flessibile rinforzato nero.

Reinforced black flexible hose.

Flexible renforcé noir.

120-01	€	5,80
150-01	€	6,30
200-01	€	6,80
120-BOX	€	6,30
150-BOX	€	6,80
200-BOX	€	7,30

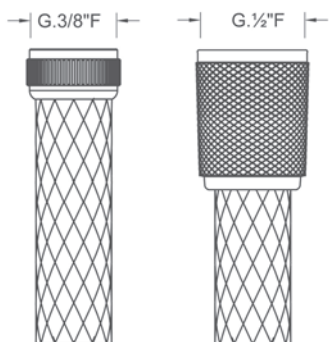

FLO32BIN

PVC

Flessibile rinforzato bianco/azzurro.

Reinforced white/bluish flexible hose.

Flexible renforcé blanc/bleu.

120-01	€	7,10
150-01	€	7,60
200-01	€	8,10
120-BOX	€	7,60
150-BOX	€	8,10
200-BOX	€	8,60

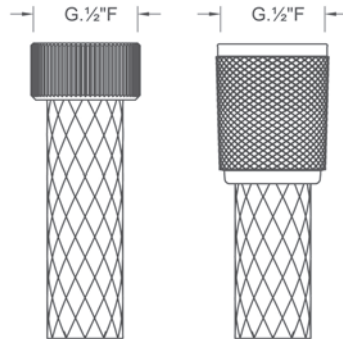

FL001GIN

PVC

Flessibile rinforzato grigio.
Reinforced gray flexible hose.
Flexible renforcé gris.

120-01	€	6,50
150-01	€	6,95
200-01	€	7,90
120-BOX	€	7,00
150-BOX	€	7,45
200-BOX	€	8,40

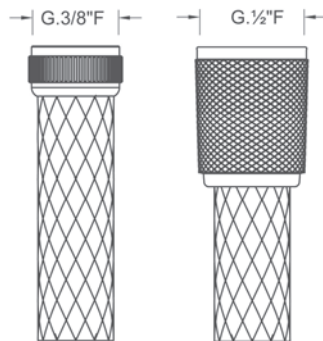

FL032NEN

PVC

Flessibile rinforzato nero.
Reinforced black flexible hose.
Flexible renforcé noir.

120-01	€	7,10
150-01	€	7,60
200-01	€	8,10
120-BOX	€	7,60
150-BOX	€	8,10
200-BOX	€	8,60

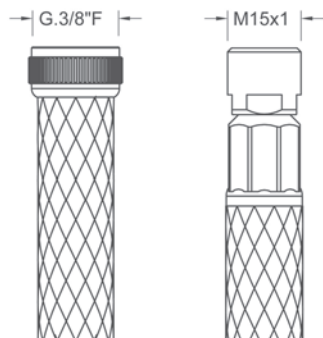

FL034BIN

PVC

Flessibile girevole rinforzato bianco/azzurro.
Reinforced swivel white/bluish flexible hose.
Flexible tournant renforcé blanc/bleu.

120-01	€	8,50
150-01	€	9,10
120-BOX	€	9,00
150-BOX	€	9,60

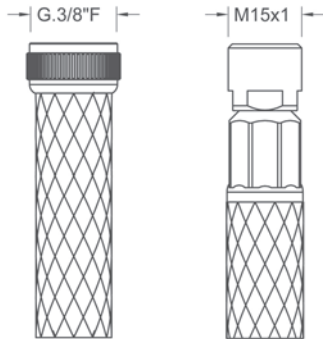

FLO34NEN

PVC

Flessibile rinforzato nero.

Reinforced swivel black flexible hose.

Flexible renforcé noir.

120-01	€	8,50
150-01	€	9,10
120-BOX	€	9,00
150-BOX	€	9,60

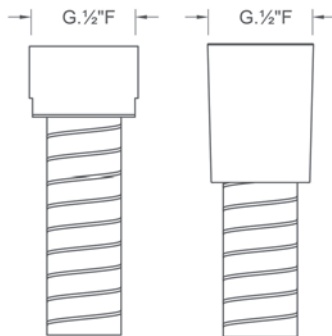

FLO15N

PVC

Flessibile sovrastampato ULTRAFLEX.

Overprinted ULTRAFLEX flexible hose.

Flexible surimprimé ULTRAFLEX.

120-01	€	12,00
150-01	€	13,00
175-01	€	13,50
200-01	€	14,50
120-BOX	€	12,50
150-BOX	€	13,50
175-BOX	€	14,00
200-BOX	€	14,50

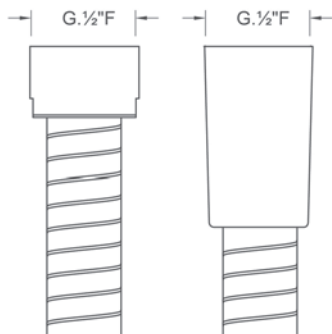

FLO13N

PVC

Flessibile girevole sovrastampato ULTRAFLEX.

Overprinted ULTRAFLEX swivel flexible hose.

Flexible tournant surimprimé ULTRAFLEX.

120-01	€	13,50
150-01	€	14,50
175-01	€	15,00
200-01	€	16,00
120-BOX	€	14,00
150-BOX	€	15,00
175-BOX	€	15,50
200-BOX	€	16,50

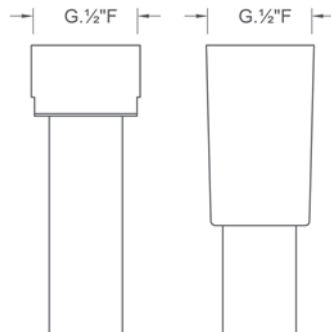

FLO08BI

PVC

Flessibile girevole sovrastampato RAGNO bianco.

Overprinted RAGNO white swivel flexible hose.

Flexible tournant surimprimé RAGNO blanc.

120-01	€	14,80
150-01	€	15,30
175-01	€	16,50
200-01	€	17,00
120-BOX	€	15,30
150-BOX	€	15,80
175-BOX	€	17,00
200-BOX	€	17,50

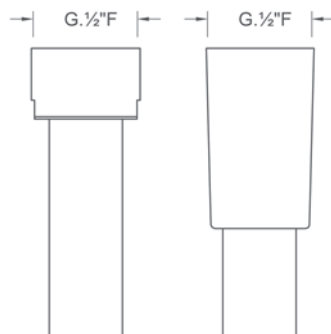

FLO08NE

PVC

Flessibile girevole sovrastampato RAGNO nero.

Overprinted RAGNO black swivel flexible hose.

Flexible tournant surimprimé RAGNO noir.

120-01	€	14,80
150-01	€	15,30
175-01	€	16,50
200-01	€	17,00
120-BOX	€	15,30
150-BOX	€	15,80
175-BOX	€	17,00
200-BOX	€	17,50

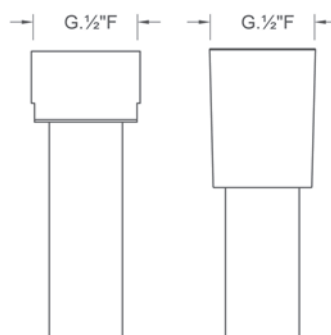

FLO09SI

PVC

Flessibile sovrastampato SILVER.

Overprinted SILVER flexible hose.

Flexible surimprimé SILVER.

120-01	€	16,00
150-01	€	17,50
200-01	€	20,70
120-BOX	€	16,50
150-BOX	€	18,00
200-BOX	€	21,20

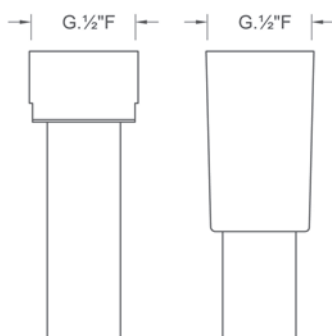

FL008SI

PVC

Flessibile girevole sovrastampato SILVER.

Overprinted SILVER swivel flexible hose.

Flexible tournant surimprimé SILVER.

120-01	€	17,50
150-01	€	19,00
175-01	€	20,50
200-01	€	22,20
120-BOX	€	18,00
150-BOX	€	19,50
175-BOX	€	21,00
200-BOX	€	22,70

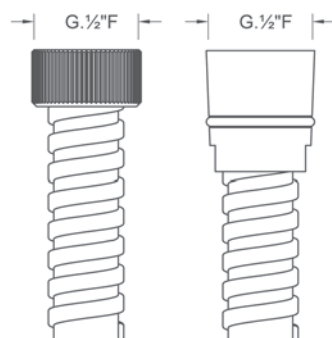

FL028

ACCIAIO INOX | Stainless steel | Acier inox

Flessibile doppia aggraffatura 1500 mm.

Double interlock flexible hose 1500 mm.

Flexible double agrafage 1500 mm.

150-01	€	9,50
150-BOX	€	10,00

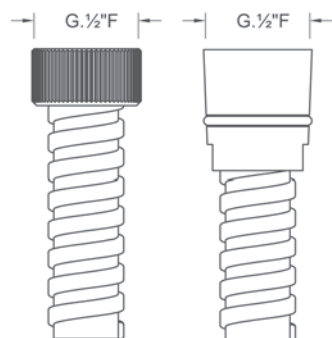

FL027

ACCIAIO INOX | Stainless steel | Acier inox

Flessibile doppia aggraffatura 1750 mm.

Double interlock flexible hose 1750 mm.

Flexible double agrafage 1750 mm.

175-01	€	11,00
175-BOX	€	11,50

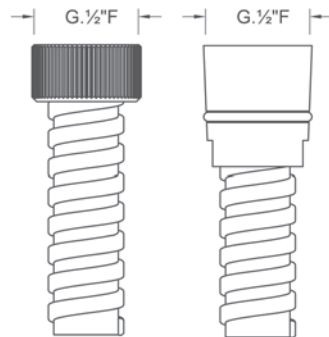

FL020

ACCIAIO INOX | Stainless steel | Acier inox

Flessibile doppia aggraffatura 2000 mm.

Double interlock flexible hose 2000 mm.

Flexible double agrafage 2000 mm.

200-01	€	13,70
200-BOX	€	14,20

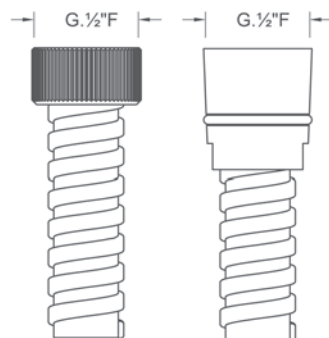

FL019

ACCIAIO INOX | Stainless steel | Acier inox

Flessibile estensibile doppia aggraffatura 1500/2000 mm.

Extendible double interlock flexible hose 1500/2000 mm.

Flexible double agrafage extensible 1500/2000 mm.

CR	€	12,50
----	---	--------------

sacchetto | bag | sac

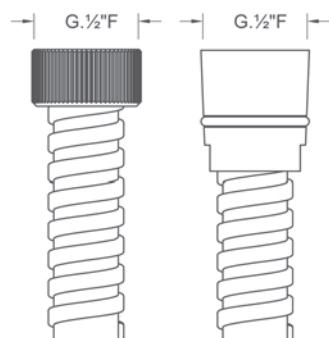

FL021

OTTONE | Brass | Laiton

Flessibile aggraffatura semplice.

Single interlock flexible hose.

Flexible agrafage simple.

120-01	€	12,10
150-01	€	13,50
200-01	€	18,00
120-BOX	€	12,60
150-BOX	€	14,00
200-BOX	€	18,50

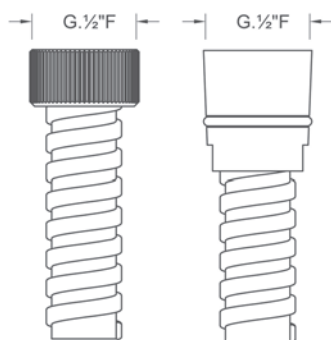

FL022

OTTONE | Brass | Laiton

Flessibile doppia aggraffatura.

Double interlock flexible hose.

Flexible double agrafage.

120-01	€	18,50
150-01	€	20,00
175-01	€	25,50
200-01	€	27,50
120-BOX	€	19,00
150-BOX	€	20,50
175-BOX	€	26,00
200-BOX	€	28,00
BS 120-01	€	32,75
RS 120-01	€	32,75
ORO 120-01	€	46,00

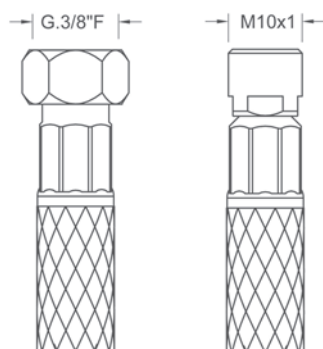

FL061

ACCIAIO INOX | Stainless steel | Acier inox

Flessibile DN6 350 mm.

DN6 flexible hose 350 mm.

Flexible DN6 350 mm.

N - RO - BL	€	8,10
-------------	---	-------------

sacchetto | bag | sac

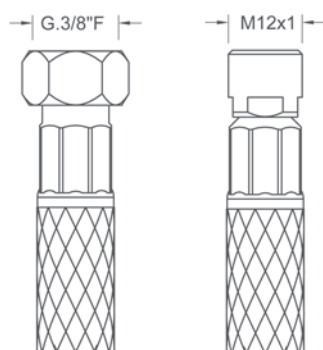

FL075

ACCIAIO INOX | Stainless steel | Acier inox

Flessibile DN8 400 mm.

DN8 flexible hose 400 mm.

Flexible DN8 400 mm.

RO - BL	€	8,50
---------	---	-------------

sacchetto | bag | sac

FL077

ACCIAIO INOX | Stainless steel | Acier inox

Flessibile DN8 600 mm.
DN8 flexible hose 600 mm.
Flexible DN8 600 mm.

N - RO - BL

€ **9,00**

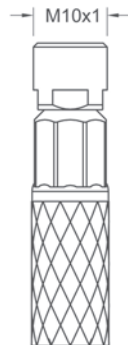
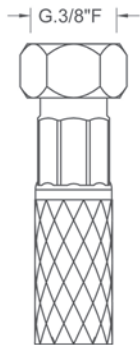

sacchetto | bag | sac

FL079RO/BL

ACCIAIO INOX | Stainless steel | Acier inox

Flessibile DN8 400 mm.
DN8 flexible hose 400 mm.
Flexible DN8 400 mm.

€ **12,00**

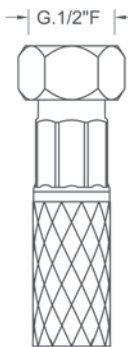
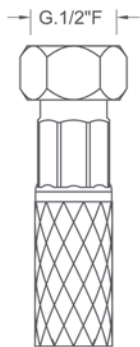

sacchetto | bag | sac

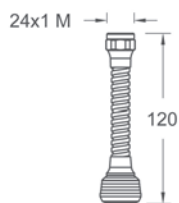

CAN004

OTTONE | Brass | Laiton

Cannuccia doppia aggraffatura con aeratore doppiogetto.

Faucet flexible attachments with double interlock and double jet tap spout aerator.

Flexible prolongeur, double agrafage avec aérateur jet double.

CR € **16,50**

sacchetto | bag | sac

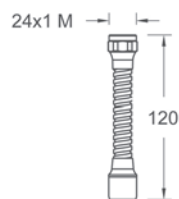

CAN006

OTTONE | Brass | Laiton

Cannuccia doppia aggraffatura con aeratore.

Faucet flexible attachments with double interlock and tap spout aerator.

Flexible prolongeur, double agrafage avec aérateur.

CR € **15,50**

sacchetto | bag | sac

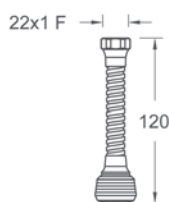

CAN002

OTTONE | Brass | Laiton

Cannuccia doppia aggraffatura con aeratore doppiogetto.

Faucet flexible attachments with double interlock and double jet tap spout aerator.

Flexible prolongeur, double agrafage avec aérateur jet double.

CR € **15,00**

sacchetto | bag | sac

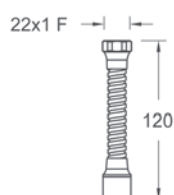

CAN001

OTTONE | Brass | Laiton

Cannuccia doppia aggraffatura con aeratore.

Faucet flexible attachments with double interlock and tap spout aerator.

Flexible prolongeur, double agrafage avec aérateur.

CR € **13,00**

sacchetto | bag | sac

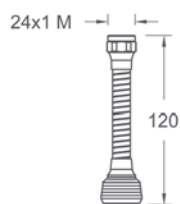
**CAN007**

OTTONE/PVC | Brass/PVC | Laiton/PVC

Cannuccia con aeratore doppiogetto.

*Faucet flexible attachments with double jet tap spout aerator.**Flexible prolongeur avec aérateur jet double.*CR € **12,50**

sacchetto | bag | sac

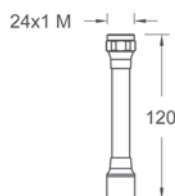
**CAN008**

OTTONE/PVC | Brass/PVC | Laiton/PVC

Cannuccia con aeratore.

*Faucet flexible attachments with tap spout aerator.**Flexible prolongeur avec aérateur.*CR € **11,50**

sacchetto | bag | sac

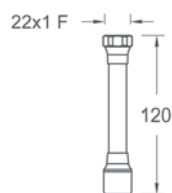
**CAN005**

OTTONE/PVC | Brass/PVC | Laiton/PVC

Cannuccia con aeratore.

*Faucet flexible attachments with tap spout aerator.**Flexible prolongeur avec aérateur.*CR € **10,50**

sacchetto | bag | sac

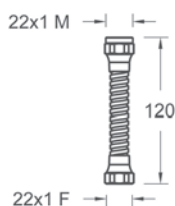
**CAN001-CRSA**

OTTONE | Brass | Laiton

Cannuccia doppia aggraffatura 120 mm.

*Faucet flexible attachments with double interlock 120 mm.**Flexible prolongeur, double agrafage 120 mm.*CR € **12,00**

sacchetto | bag | sac

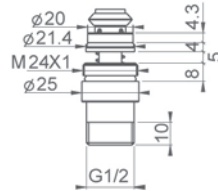

DV001 MINIMALISTA

OTTONE | Brass | Laiton



Deviatore manuale/automatico.

Manual/automatic diverter.

Inverseur manuel/automatique.

CR

€ 800,00

scatola | box | boîte 50 pz. | pcs.

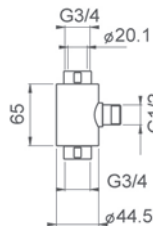

DV014

OTTONE | Brass | Laiton



Deviatore a colonna MINIMALISTA tondo, senza pomolo, per tubo Ø 20 mm, attacchi 3/4" M x 3/4" F. Disponibile anche per tubo Ø 18 mm e attacchi 1/2" F.

MINIMALISTA column diverter, without knob, for hose Ø 20 mm, connections 3/4" M x 3/4" F.

Also available for tube Ø 18 mm, connections 1/2" F.

Inverseur à colonne MINIMALISTA rond, sans bouton, pour tube Ø 20 mm, raccords 3/4" M x 3/4" F.

Disponible aussi pour tube Ø 18 mm et raccords 1/2" F.

CR

€ 65,50

scatola | box | boîte

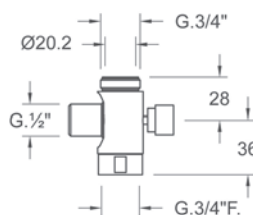

DV013

OTTONE | Brass | Laiton

Deviatore a colonna con pomolo, attacchi 3/4" M/F con sede per valvola di non ritorno, foro Ø 20 mm.

Column diverter with knob, connections 3/4" M/F, with non-return valve seat, hole Ø 20 mm.

Inverseur à colonne avec bouton, raccords 3/4" M/F avec siège pour valve de non retour, trou Ø 20 mm.

CR

€ 35,00

scatola | box | boîte

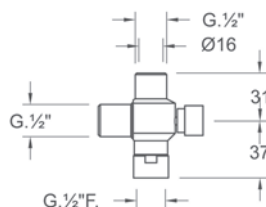

DV012

OTTONE | Brass | Laiton

Deviatore a colonna con pomolo, attacchi 1/2" M/F con sede per valvola di non ritorno, foro Ø 16 mm. Disponibile anche con attacchi 3/4" M x 1/2" F e 1/2" M x 3/4" F.

Column diverter, connections 1/2" M/F, hole Ø 16 mm with knob and non-return valve seat.

Also available with connections 3/4" M x 1/2" F and 1/2" M x 3/4" F.

Inverseur à colonne avec bouton, raccords 1/2" M/F avec siège pour valve de non retour, trou Ø 16 mm.

Disponibile aussi avec raccords 3/4" M x 1/2" F e 1/2" M x 3/4" F.

CR € **31,00**

scatola | box | boîte

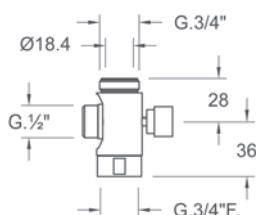

DV002

OTTONE | Brass | Laiton

Deviatore a colonna con pomolo, attacchi 3/4" M/F, foro Ø 18 mm.

Column diverter with knob, connections 3/4" M/F, hole Ø 18 mm.

Inverseur à colonne avec bouton, raccords 3/4" M/F, trou Ø 18 mm.

CR € **31,00**

scatola | box | boîte

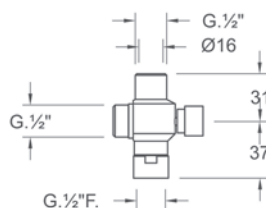

DV011

OTTONE | Brass | Laiton

Deviatore a colonna con pomolo, attacchi 1/2" M/F, foro Ø 16 mm.

Disponibile anche con attacchi 3/4" M x 1/2" F e 1/2" M x 3/4" F.

Column diverter with knob, connections 1/2" M/F, hole mm Ø 16 mm.

Also available with connections 3/4" M x 1/2" F and 1/2" M x 3/4" F.

Inverseur à colonne avec bouton, raccords 1/2" M/F, trou Ø 16 mm.

Disponibile aussi avec raccords 3/4" M x 1/2" F e 1/2" M x 3/4" F.

CR € **31,00**

scatola | box | boîte

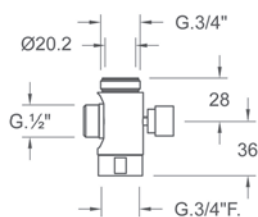

DV021

OTTONE | Brass | Laiton

Deviatore a colonna con pomolo, attacchi 3/4" M/F, foro Ø 20 mm.

Column diverter with knob, connections 3/4" M/F, hole Ø 20 mm.

Inverseur à colonne avec bouton, raccords 3/4" M/F, trou Ø 20 mm.

CR € **31,00**

scatola | box | boîte

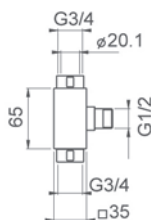

DV026

OTTONE | Brass | Laiton



Deviatore a colonna MINIMALISTA quadro, senza pomolo, per tubo Ø 20 mm, attacchi 3/4" M x 3/4" F. Disponibile anche per tubo Ø 18 mm e attacchi 1/2" F.

MINIMALISTA square column diverter, without knob, for tube Ø 20 mm, connections 3/4" M x 3/4" F.

Also available for tube Ø 18 mm, connections 1/2" F.

Inverseur à colonne MINIMALISTA carré, sans bouton, pour tube Ø 20 mm, raccords 3/4" M x 3/4" F.

Disponible aussi pour tube Ø 18 mm et raccords 1/2" F.

CR € **70,00**

scatola | box | boîte

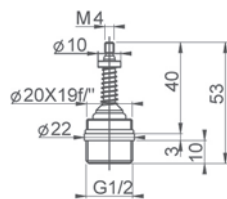

DV003 LEGO

OTTONE | Brass | Laiton

Deviatore manuale/automatico.

Manual/automatic diverter.

Inverseur manuel/automatique.

CR € **638,00**

scatola | box | boîte 100 pz. | pcs.

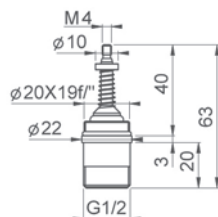

DV004 LEGO TOP

OTTONE | Brass | Laiton

Deviatore manuale/automatico con sede valvola di non ritorno.

Manual/automatic diverter with back flow-valve seat.

Inverseur manuel/automatique avec siège valve non retour.

CR € **1085,00**

scatola | box | boîte 120 pz. | pcs.

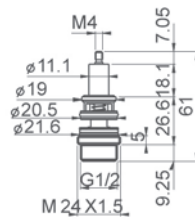

DV005 COMPACT

OTTONE | Brass | Laiton

Deviatore manuale/automatico.

Manual/automatic diverter.

Inverseur manuel/automatique.

CR

€ 1095,00

scatola | box | boîte 110 pz. | pcs.

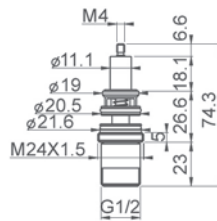

DV020 COMPACT TOP

OTTONE | Brass | Laiton

Deviatore manuale/automatico con sede valvola di non ritorno.

Manual/automatic diverter with back-flow valve slot.

Inverseur manuel/automatique avec siège valve non retour.

CR

€ 1150,00

scatola | box | boîte 120 pz. | pcs.

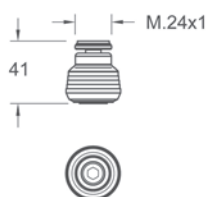

SNA011

OTTONE | Brass | Laiton

Snodo con aeratore doppiogetto 24x1M.
Ball joint with double jet tap spout aerator 24x1M.
Rotule avec aérateur jet double 24x1M.

CR € **6,50**

sacchetto | bag | sac

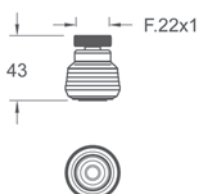

SNA012

OTTONE | Brass | Laiton

Snodo con aeratore doppiogetto 22x1F.
Ball joint with double jet tap spout aerator 22x1F.
Rotule avec aérateur jet double 22x1F.

CR € **7,00**

sacchetto | bag | sac

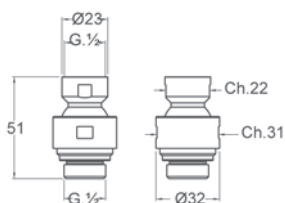

SN011

OTTONE | Brass | Laiton

Snodo per soffioni 1/2Fx1/2M.
Swivel joint for shower heads 1/2Fx1/2M.
Rotule pour pomme de douche 1/2Fx1/2M.

CR € **16,50**

sacchetto | bag | sac

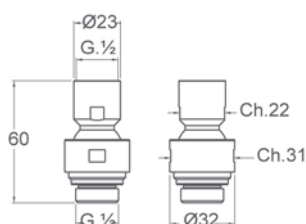

SN012

OTTONE | Brass | Laiton

Snodo per soffioni con raccordo sferico lungo 1/2Fx1/2M.
Swivel ball joint for shower heads, with long spherical coupling 1/2Fx1/2M.
Rotule pour pomme de douche avec raccord sphérique long 1/2Fx1/2M.

CR € **18,50**

sacchetto | bag | sac

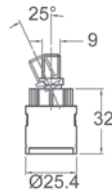

CT006

CERAMICA | Ceramic | Ceramique

Cartuccia Ø 25 mm, senza distributore.
Cartridge Ø 25 mm, without distributor.
Cartouche Ø 25 mm, sans distributeur.

€ 20,00

sacchetto | bag | sac

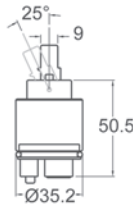

CT002-01

CERAMICA | Ceramic | Ceramique

Cartuccia Ø 35 mm, con distributore.
Cartridge Ø 35 mm, with distributor.
Cartouche Ø 35 mm, avec distributeur.

€ 15,00

sacchetto | bag | sac

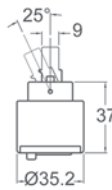

CT002

CERAMICA | Ceramic | Ceramique

Cartuccia Ø 35 mm, senza distributore.
Cartridge Ø 35 mm, without distributor.
Cartouche Ø 35 mm, sans distributeur.

€ 15,00

sacchetto | bag | sac

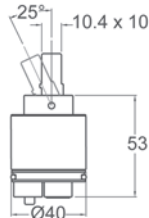

CT005-01

CERAMICA | Ceramic | Ceramique

Cartuccia Ø 40 mm, con distributore.
Cartridge Ø 40 mm, with distributor.
Cartouche Ø 40 mm, avec distributeur.

€ 15,00

sacchetto | bag | sac

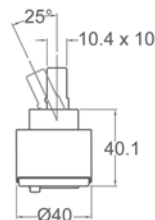

CT005

CERAMICA | Ceramic | Ceramique

Cartuccia Ø 40 mm, senza distributore.
Cartridge Ø 40 mm, without distributor.
Cartouche Ø 40 mm, sans distributeur.

€ 15,00

sacchetto | bag | sac

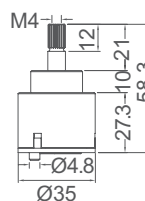

CT007

CERAMICA | Ceramic | Ceramique

Cartuccia deviatrice Ø 35 mm, senza distributore.
Diverter cartridge Ø 35 mm, without distributor.
Cartouche déviatrice Ø 35 mm, sans distributeur.

€ 25,00

sacchetto | bag | sac

ECCENTRICI E COPRIFORO
S-connectors and waste plugs | Excentriques et bondes

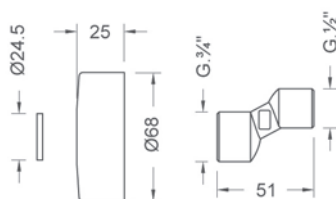

RO017 MINIMALISTA

OTTONE | Brass | Laiton

Eccentrico con rosone 3/4", Ø 68 mm con guarnizione.

S-connector with escutcheon 3/4" for mixer, Ø 68 mm with gasket.

Excentrique avec rosace 3/4", Ø 68 mm avec joint.

CR € **9,50**

sacchetto | bag | sac

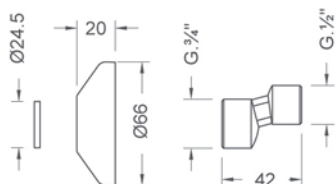

RO015

OTTONE | Brass | Laiton

Eccentrico con rosone 3/4", Ø 66 mm con guarnizione.

S-connector with escutcheon 3/4", Ø 66 mm with gasket.

Excentrique avec rosace 3/4", Ø 66 mm avec joint.

CR € **5,50**

sacchetto | bag | sac

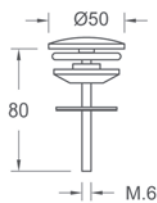

TAP001

OTTONE | Brass | Laiton

Tappo copriforo.

Waste plug.

Bonde.

CR € **6,50**

sacchetto | bag | sac

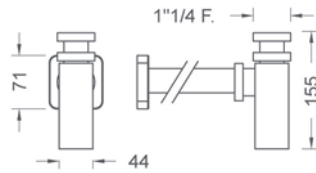

SIFQ001 MINIMALISTA

OTTONE | Brass | Laiton

Sifone quadro per lavabo attacco 1" 1/4, tubo 300 mm.

Square siphon for basin connection 1" 1/4, pipe 300 mm.

Siphon carré pour lavabo raccord 1" 1/4, tube 300 mm.

CR € **131,50**

scatola | box | boîte

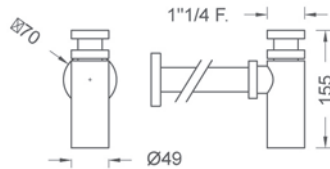

SIFT001 MINIMALISTA

OTTONE | Brass | Laiton

Sifone tondo per lavabo attacco 1" 1/4, tubo 300 mm.

Round siphon for basin connection 1" 1/4, pipe 300 mm.

Siphon rond pour lavabo raccord 1" 1/4, tube 300 mm.

CR € **100,50**

scatola | box | boîte

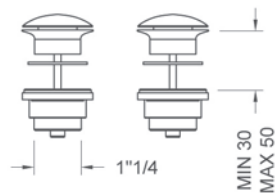

SCAR001

OTTONE | Brass | Laiton

Scarico universale click-clack attacco 1" 1/4.

Click-clack universal waste connection 1" 1/4.

Drainage universel click-clack raccord 1" 1/4.

CR € **49,50**

scatola | box | boîte

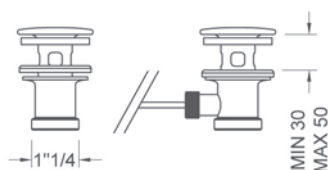

SCAR002

OTTONE | Brass | Laiton

Scarico attacco 1" 1/4.

Waste connection 1" 1/4.

Drainage raccord 1" 1/4.

CR € **21,00**

scatola | box | boîte

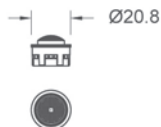

FIL001

POM-C/SILICONE

Filtro aeratore limitatore di portata 4 l/min, giallo.
Tap spout aerator filter with water flow regulator 4 l/min, yellow.
Filtre aérateur limiteur de débit 4 l/min, jaune.

€ **2,20**

4

sacchetto | bag | sac

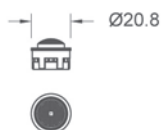

FIL002

POM-C/SILICONE

Filtro aeratore limitatore di portata 6 l/min, verde.
Tap spout aerator filter with water flow regulator 6 l/min, green.
Filtre aérateur limiteur de débit 6 l/min, vert.

€ **2,20**

6

sacchetto | bag | sac

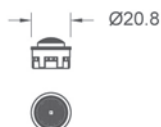

FIL003

POM-C/SILICONE

Filtro aeratore limitatore di portata 8 l/min, blu.
Tap spout aerator filter with water flow regulator 8 l/min, blue.
Filtre aérateur limiteur de débit 8 l/min, bleu.

€ **2,20**

8

sacchetto | bag | sac

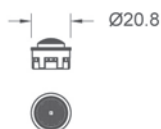

FIL004

POM-C/SILICONE

Filtro aeratore limitatore di portata 10 l/min, arancio.
Tap spout aerator filter with water flow regulator 10 l/min, orange.
Filtre aérateur limiteur de débit 10 l/min, orange.

€ **2,20**

10

sacchetto | bag | sac



FIE002

POM-C/ACCIAIO | POM-C/Steel | POM-C/Acier

Filtro aeratore economizzatore 6 l/min a 3 bar, verde.
Tap spout aerator filter with water saver 6 l/min at 3 bar, green.
Filtre aérateur économiseur 6 l/min sous 3 bar, vert.

€ **0,45**

6

sacchetto | bag | sac



FIE003

POM-C/ACCIAIO | POM-C/Steel | POM-C/Acier

Filtro aeratore economizzatore 8 l/min a 3 bar, blu.
Tap spout aerator filter with water saver 8 l/min at 3 bar, blue.
Filtre aérateur économiseur 8 l/min sous 3 bar, bleu.

€ **0,45**

8

sacchetto | bag | sac



FIE004

POM-C/ACCIAIO | POM-C/Steel | POM-C/Acier

Filtro aeratore economizzatore 10 l/min a 3 bar, arancio.
Tap spout aerator filter with water saver 10 l/min at 3 bar, orange.
Filtre aérateur économiseur 10 l/min sous 3 bar, orange.

€ **0,45**

10

sacchetto | bag | sac



FI005

POM-C/ACCIAIO | POM-C/Steel | POM-C/Acier

Filtro aeratore classe B norme UNI EN 246 per corpo aeratori, 22x1F e 24x1M.

Tap spout aerator filter class B UNI EN 246 standards for aerators, 22x1F and 24x1M.

Filtre aérateur classe B norme UNI EN 246 pour corps aérateurs 22x1F et 24x1M.

€ **0,45**

sacchetto | bag | sac



FI006

POM-C/ACCIAIO | POM-C/Steel | POM-C/Acier

Filtro aeratore classe B norme UNI EN 246 per corpo aeratori, 28x1M.

Tap spout aerator filter class B UNI EN 246 standards for aerators, 28x1M.

Filtre aérateur classe B norme UNI EN 246 pour corps aérateurs 28x1M.

€ **1,10**

sacchetto | bag | sac

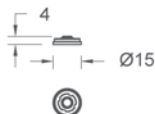

LIP04DN15

POM-C/SILICONE

Limitatori di portata 4 l/min, giallo.
Water flow regulator 4 l/min, yellow.
Limiteur de débit 4 l/min, jaune.

€ **1,10**

4

sacchetto | bag | sac

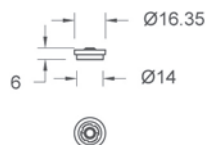

LIP06DN15

POM-C/SILICONE

Limitatori di portata 6 l/min, verde.
Water flow regulator 6 l/min, green.
Limiteur de débit 6 l/min, vert.

€ **1,10**

6

sacchetto | bag | sac

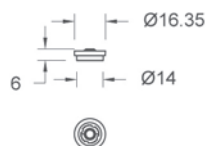

LIP08DN15

POM-C/SILICONE

Limitatori di portata 8 l/min, blu.
Water flow regulator 8 l/min, blue.
Limiteur de débit 8 l/min, bleu.

€ **1,10**

8

sacchetto | bag | sac

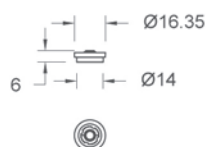

LIP10DN15

POM-C/SILICONE

Limitatori di portata 10 l/min, arancio.
Water flow regulator 10 l/min, orange.
Limiteur de débit 10 l/min, orange.

€ **1,10**

10

sacchetto | bag | sac

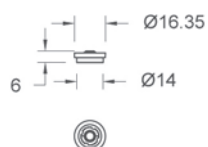

LIP12DN15

POM-C/SILICONE

Limitatori di portata 12 l/min, rosso.
Water flow regulator 12 l/min, red.
Limiteur de débit 12 l/min, rouge.

€ **1,10**

12

sacchetto | bag | sac

AER005

OTTONE | Brass | Laiton

Aeratore 24x1M con retina metallica.

Tap spout aerator 24x1M with metal net.

Aérateur 24x1M avec filet métallique.

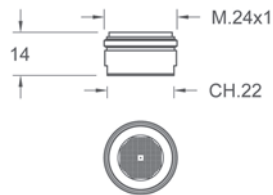

BI		€	2,45
CR		€	1,85
BS - ORO		€	2,45
AER003	BLISTER 6 PZ.	€	8,00
AER002	BOX 10 PZ.	€	15,50
AER001	BOX 500 PZ.	€	650,00

AER005-LIMI 4-6-8-10

OTTONE | Brass | Laiton

Aeratore 24x1M con limitatore di portata.

Indicare nell'ordine la portata scelta (4-6-8-10).

Tap spout aerator 24x1M with water flow regulator.

Please select the flow rate when placing the order (4-6-8-10).

Aérateur 24x1M avec limiteur de débit.

Indiquer en commande le débit désiré (4-6-8-10).

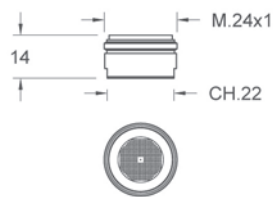

CR		€	2,80
AER003	BLISTER 6 PZ.	€	14,00
AER002	BOX 10 PZ.	€	22,00
AER001	BOX 500 PZ.	€	1100,00

4 6 8 10

AER005-ECO 6-8-10

OTTONE | Brass | Laiton

Aeratore 24x1M con economizzatore.

Indicare nell'ordine il modello scelto (6-8-10).

Tap spout aerator 24x1M with water saver.

Please select the model when placing the order (6-8-10).

Aérateur 24x1M avec économiseur.

Indiquer en commande le modèle désiré (6-8-10).

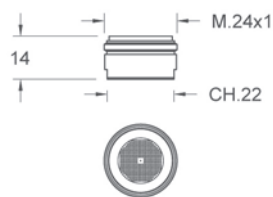

CR		€	1,95
AER003	BLISTER 6 PZ.	€	7,70
AER002	BOX 10 PZ.	€	15,00
AER001	BOX 500 PZ.	€	643,00

6 8 10

AERATORI

Tap spout aerators | Aérateurs

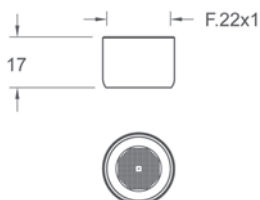

AER010

OTTONE | Brass | Laiton

Aeratore 22x1F.

Tap spout aerator 22x1F.

Aérateur 22x1F.

BI		€	2,55
CR		€	1,95
BS - ORO		€	2,55
AER008	BLISTER 6 PZ.	€	8,25
AER007	BOX 10 PZ.	€	15,50
AER006	BOX 500 PZ.	€	688,00

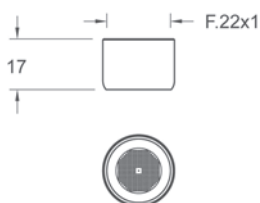

AER010-LIMI 4-6-8-10

OTTONE | Brass | Laiton

Aeratore 22x1F con limitatore di portata.

Indicare nell'ordine la portata scelta (4-6-8-10).

Tap spout aerator 22x1F with water flow regulator.

Please select the flow rate when placing the order (4-6-8-10).

Aérateur 22x1F avec limiteur de débit.

Indiquer en commande le débit désiré (4-6-8-10).

CR		€	2,80
AER008	BLISTER 6 PZ.	€	14,00
AER007	BOX 10 PZ.	€	22,00
AER006	BOX 500 PZ.	€	1100,00

4 6 8 10

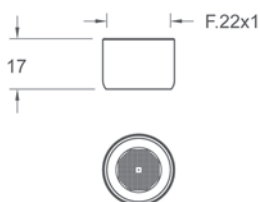

AER010-ECO 6-8-10

OTTONE | Brass | Laiton

Aeratore 22x1F con economizzatore.

Indicare nell'ordine il modello scelto (6-8-10).

Tap spout aerator 22x1F with water saver.

Please select the model when placing the order (6-8-10).

Aérateur 22x1F avec économiseur.

Indiquer en commande le modèle désiré (6-8-10).

CR		€	1,95
AER008	BLISTER 6 PZ.	€	7,70
AER007	BOX 10 PZ.	€	15,00
AER006	BOX 500 PZ.	€	643,00

6 8 10

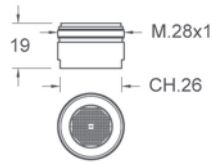

AER011

OTTONE | Brass | Laiton

Aeratore 28x1M.

Tap spout aerator 28x1M.

Aérateur 28x1M.

BOX 320 PZ. € **825,00**

scatola | box | boîte

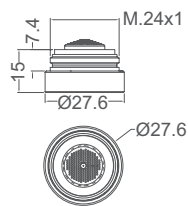

AER015

OTTONE | Brass | Laiton

Aeratore 24x1M con limitatore di portata.

Tap spout aerator 24x1M with water flow regulator.

Aérateur 24x1M avec limiteur de débit.

CR € **45,00**



scatola | box | boîte 5 pz. | pcs.
+ 1 chiavetta | key | clé

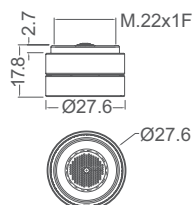

AER016

OTTONE | Brass | Laiton

Aeratore 22x1F con limitatore di portata.

Tap spout aerator 22x1F with water flow regulator.

Aérateur 22x1F avec limiteur de débit.

CR € **65,00**



scatola | box | boîte 5 pz. | pcs.
+ 1 chiavetta | key | clé

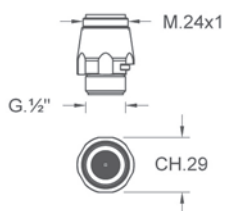

AER017 AMERICA

OTTONE | Brass | Laiton

Aeratore 24x1M innesto rapido 1/2" M.
Tap spout aerator 24x1M quick connector 1/2" M.
Aérateur 24x1M greffe rapide 1/2" M.

CR € **12,50**

sacchetto | bag | sac

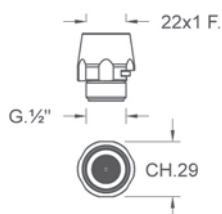

AER017-01 AMERICA

OTTONE | Brass | Laiton

Aeratore 22x1F innesto rapido 1/2" M.
Tap spout aerator 22x1F quick connector 1/2" M.
Aérateur 22x1F greffe rapide 1/2" M.

CR € **11,00**

sacchetto | bag | sac

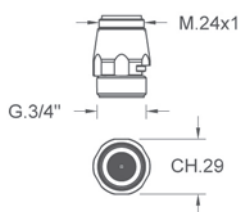

AER018 AMERICA

OTTONE | Brass | Laiton

Aeratore 24x1M innesto rapido 3/4" M.
Tap spout aerator 24x1M quick connector 3/4" M.
Aérateur 24x1M greffe rapide 3/4" M.

CR € **15,00**

sacchetto | bag | sac

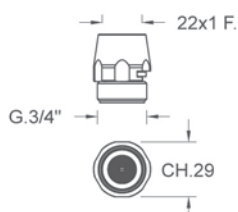

AER018-01 AMERICA

OTTONE | Brass | Laiton

Aeratore 22x1F innesto rapido 3/4" M.
Tap spout aerator 22x1F quick connector 3/4" M.
Aérateur 22x1F greffe rapide 3/4" M.

CR € **14,00**

sacchetto | bag | sac

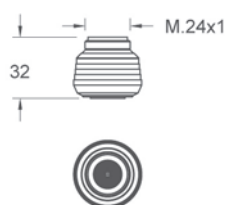

AER019

ABS

Aeratore 24x1M doppio getto.
Double jet tap spout aerator 24x1M.
Aérateur 24x1M double jet.

CR € **4,50**

sacchetto | bag | sac

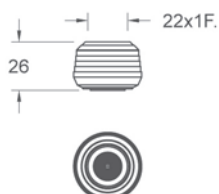

AER020

ABS

Aeratore 22x1F doppio getto con guarnizione filtro.
Double jet tap spout aerator 22x1F with filter gasket.
Aérateur 22x1F double jet avec joint filtre.

CR € **2,80**

sacchetto | bag | sac

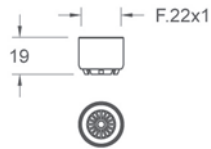

ROM009

OTTONE | Brass | Laiton

Rompigetto 22x1F bassa pressione.

Flow breaker 22x1F low water pressure.

Brise jet 22x1F basse pression.

BOX 500 PZ. € **550,00**

scatola | box | boîte



ROM010

OTTONE | Brass | Laiton

Rompigetto 24x1M bassa pressione.

Flow breaker 24x1M low water pressure.

Brise jet 24x1M basse pression.

BOX 500 PZ. € **550,00**

scatola | box | boîte

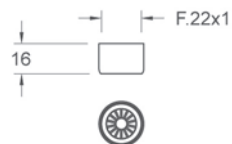

ROM002

OTTONE | Brass | Laiton

Rompigetto 22x1F.

Flow breaker 22x1F.

Brise jet 22x1F.

BOX 500 PZ. € **500,00**

ROM003 BOX 10 PZ. € **11,00**

scatola | box | boîte

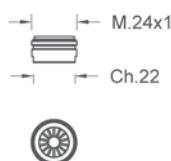

ROM004

OTTONE | Brass | Laiton

Rompigetto 24x1M.

Flow breaker 24x1M.

Brise jet 24x1M.

BOX 500 PZ. € **500,00**

ROM005 BOX 10 PZ. € **11,00**

scatola | box | boîte

ROMPIGETTO

Tap spout flow breakers | Brises jet

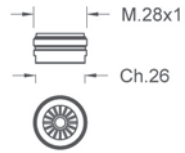

ROM006

OTTONE | Brass | Laiton

Rompigetto 28x1M.

Flow breaker 28x1M.

Brise jet 28x1M.

BOX 400 PZ. € **470,00**

ROM007 BOX 10 PZ. € **12,50**

scatola | box | boîte

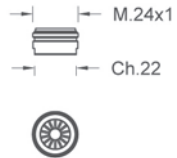

ROM008

ABS

Rompigetto 24x1M.

Flow breaker 24x1M.

Brise jet 24x1M.

BOX 500 PZ. € **350,00**

scatola | box | boîte



RC019

OTTONE | Brass | Laiton

Raccordo innesto rapido per aeratore AMERICA 3/4" M con OR.

Quick connector for AMERICA tap spout aerator 3/4" M with OR.

Raccord greffe rapide pour aérateur AMERICA 3/4" M avec OR.

CR € **5,50**

sacchetto | bag | sac

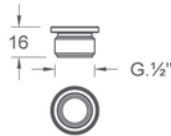

RC018

OTTONE | Brass | Laiton

Raccordo innesto rapido per aeratore AMERICA 1/2" M con OR.

Quick connector for AMERICA tap spout aerator 1/2" M with OR.

Raccord greffe rapide pour aérateur AMERICA 1/2" M avec OR.

CR € **5,00**

sacchetto | bag | sac

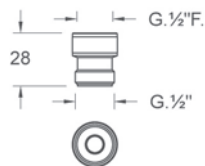

RC005

OTTONE | Brass | Laiton

Raccordo con valvola di non ritorno 1/2" Mx1/2" F.

Connector with non-return valve 1/2" Mx1/2" F.

Raccord avec valve de non retour 1/2" Mx1/2" F.

CR € **5,50**

sacchetto | bag | sac

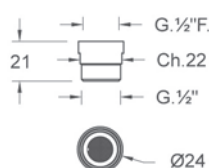

RC007-LIMI 6-8-10-12

OTTONE | Brass | Laiton

Raccordo con limitatore di portata 1/2" Mx1/2" F. Indicare nell'ordine la portata scelta (6-8-10-12).

Connector with water flow regulator 1/2" Mx1/2" F. Please select the flow rate when placing the order. (6-8-10-12).

Raccord avec limiteur de débit 1/2" Mx1/2" F.

Indiquer en commande le débit désiré (6-8-10-12).

CR € **3,50**

RC006-LIMI 6-8-10-12 BOX 90 PZ. € **249,50**

6 8 10 12

scatola | box | boîte

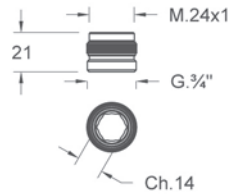

RC013

OTTONE | Brass | Laiton

Riduzione 24x1M, G. 3/4" M.

Reduction 24x1M, G. 3/4" M.

Réduction 24x1M, G. 3/4" M.

CR € **5,30**

sacchetto | bag | sac

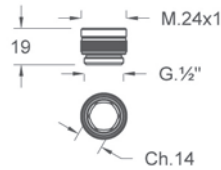

RC012

OTTONE | Brass | Laiton

Riduzione 24x1M, G. 1/2" M.

Reduction 24x1M, G. 1/2" M.

Réduction 24x1M, G. 1/2" M.

CR € **5,00**

sacchetto | bag | sac

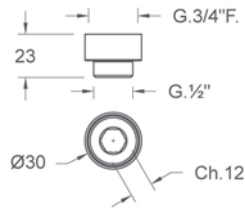

RC022

OTTONE | Brass | Laiton

Riduzione G. 1/2" M x G. 3/4" F.

Reduction G. 1/2" M x G. 3/4" F.

Réduction G. 1/2" M x G. 3/4" F.

CR € **4,50**

sacchetto | bag | sac

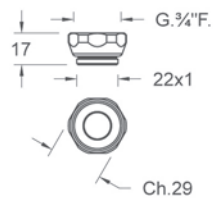

RC016

OTTONE | Brass | Laiton

Riduzione 22x1M, G. 3/4" F.

Reduction 22x1M, G. 3/4" F.

Réduction 22x1M, G. 3/4" F.

CR € **4,00**

sacchetto | bag | sac

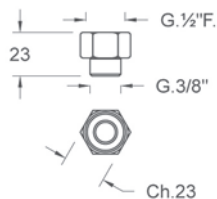

RC017

OTTONE | Brass | Laiton

Riduzione G. 3/8" M x G. 1/2" F.

Reduction G. 3/8" M x G. 1/2" F.

Réduction G. 3/8" M x G. 1/2" F.

CR € **4,00**

sacchetto | bag | sac

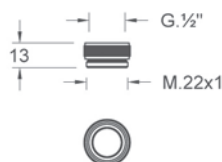

RC015

OTTONE | Brass | Laiton

Riduzione 22x1M, G. 1/2" F.

Reduction 22x1M, G. 1/2" F.

Réduction 22x1M, G. 1/2" F.

CR € **3,50**

sacchetto | bag | sac

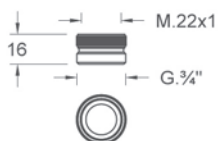

RC011

OTTONE | Brass | Laiton

Riduzione 22x1F, G. 3/4" M.

Reduction 22x1F, G. 3/4" M.

Réduction 22x1F, G. 3/4" M.

CR € **3,50**

sacchetto | bag | sac



RC014

OTTONE | Brass | Laiton

Riduzione 22x1M, G. 3/8" F.

Reduction 22x1M, G. 3/8" F.

Réduction 22x1M, G. 3/8" F.

CR € **3,50**

sacchetto | bag | sac

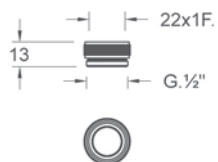

RC010

OTTONE | Brass | Laiton

Riduzione 22x1F, G. 1/2" M.

Reduction 22x1F, G. 1/2" M.

Réduction 22x1F, G. 1/2" M.

CR € **3,50**

sacchetto | bag | sac

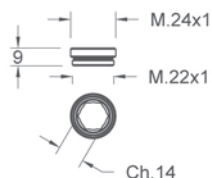

RC009

OTTONE | Brass | Laiton

Riduzione 24x1 x 22x1M/M.

Reduction 24x1 x 22x1M/M.

Réduction 24x1 x 22x1M/M.

CR € **2,50**

sacchetto | bag | sac

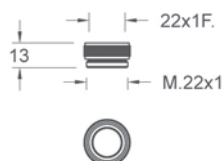

RC008-LIMI 6-8

OTTONE | Brass | Laiton

Riduzione 22x1F x 22x1M con guarnizione e limitatore 6 litri. Indicare nell'ordine la portata scelta (6-8).

Reduction 22x1F x 22x1M with gasket and water flow regulator 6 liters. Please select the flow rate when placing the order (6-8).

Réduction 22x1F x 22x1M avec joint et limiteur 6 litres. Indiquer en commande le débit désiré (6-8).

BOX 500 PZ. € **1250,00**

VALVOLE NON RITORNO
Non-return valves | Clapets anti retour



VNR005

POM-NBR

Valvola di non ritorno, passaggio totale Ø 10 mm.

Non-return valve, total bore Ø 10 mm.

Clapet anti retour passage total Ø 10 mm.

€ **1,10**

sacchetto | bag | sac



VNR001

POM-NBR

Valvola di non ritorno, passaggio totale Ø 14 mm.

Non-return valve, total bore Ø 14 mm.

Clapet anti retour passage total Ø 14 mm.

€ **1,00**

sacchetto | bag | sac



VNR003

POM-NBR

Valvola di non ritorno, passaggio totale Ø 15 mm.

Non-return valve, total bore Ø 15 mm.

Clapet anti retour passage total Ø 15 mm.

€ **1,00**

sacchetto | bag | sac

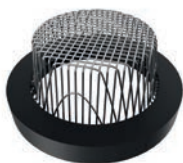

GU058

GOMMA/ACCIAIO | Rubber/Steel | Caoutchouc/Acier

Guarnizione con filtro a cupola in acciaio inox 3/4".
Gasket with stainless steel dome shaped filter 3/4".
Joint avec filtre en forme de dôme en acier inox 3/4".

€ **0,50**

sacchetto | bag | sac



GU035

GOMMA/ACCIAIO | Rubber/Steel | Caoutchouc/Acier

Guarnizione con filtro bombato in acciaio inox 1/2".
Gasket with stainless steel convex filter 1/2".
Joint avec filtre bombé en acier inox 1/2".

€ **0,40**

sacchetto | bag | sac



GU036

GOMMA/ACCIAIO | Rubber/Steel | Caoutchouc/Acier

Guarnizione con filtro bombato in acciaio inox 3/4".
Gasket with stainless steel convex filter 3/4".
Joint avec filtre bombé en acier inox 3/4".

€ **0,40**

sacchetto | bag | sac



GU038

GOMMA/ACCIAIO | Rubber/Steel | Caoutchouc/Acier

Guarnizione con filtro piano in acciaio inox 3/8".
Gasket with stainless steel flat filter 3/8".
Joint avec filtre plat en acier inox 3/8".

€ **0,30**

sacchetto | bag | sac



FI011

POM-SEBS

Filtro alimentare 1/2" con retina in POM.
Filter suitable for food contact 1/2" with POM net.
Filtre alimentaire 1/2" avec filet en POM.

€ **0,30**

sacchetto | bag | sac

COD.	P.	COD.	P.	COD.	P.
AER005.....	143	DC007.....	74	FL032BIN-200-01.....	118
AER005-ECO 6-8-10.....	143	DC010.....	73	FL032BIN-300-01.....	118
AER005-LIMI 4-6-8-10.....	143	DC011.....	73	FL032BIN-400-01.....	118
AER010.....	144	DC013.....	73	FL032NEN.....	123
AER010-ECO 6-8-10.....	144	DC029.....	119	FL034BIN.....	123
AER010-LIMI 4-6-8-10.....	144	DC031.....	119	FL034NEN.....	124
AER011.....	145	DC038.....	75	FL061.....	128
AER015.....	145	DC039.....	75	FL075.....	128
AER016.....	145	DC040.....	75	FL077.....	129
AER017.....	146	DC041.....	75	FL079RO/BL.....	129
AER017-01.....	146	DC042.....	76	GU035.....	153
AER018.....	146	DC044.....	76	GU036.....	153
AER018-01.....	146	DC049.....	74	GU038.....	153
AER019.....	146	DC051.....	76	GU058.....	153
AER020.....	146	DC052.....	76	INCA100—INCA100-3/4.....	80
BAS001.....	121	DI001.....	106	KBDQ007.....	42
BAS002.....	121	DPL001.....	116	KBDQ022-03.....	34
BAS003.....	121	DPL002.....	114	KBDQ022-06.....	35
BAS004.....	121	DS001.....	98	KBDQ022-08.....	35
BDQ001.....	54	DS001-CURVETTA.....	117	KBDQ031-01.....	36
BDQ003.....	56	DS002-C/RACCORDINO.....	98	KBDQ031-03.....	36
BDQ005.....	54	DS003-C/RACCORDINO.....	99	KBDQ031-06.....	37
BDQ006.....	57	DS004.....	99	KBDQ031-08.....	37
BDQ007.....	55	DS005.....	100	KBDT003-31.....	34
BDQ022.....	55	DS006.....	100	KBDT003-33.....	34
BDQ029.....	57	DS006-ANELLO.....	100	KBDT013-07.....	42
BDT001.....	51	DS007.....	103	KBDT017-06.....	32
BDT003.....	51	DS007-01.....	106	KBDT017-08.....	33
BDT003-02.....	52	DS007-02.....	120	KBDT020-01.....	32
BDT006.....	52	DS008.....	102	KBDT020-02.....	32
BDT007.....	52	DS009.....	103-120	KBDT027-01.....	32
BDT008.....	55	DS009-01.....	106	KBDT027-03.....	33
BDT009.....	56	DS011.....	101	KBDT027-08.....	34
BDT010.....	56	DS012.....	102	KBDT027-EASY20T.....	33
BDT012.....	55	DS013.....	118	KBDT027-EASY30T.....	33
BDT013.....	54	DS018.....	99	KBDT029-01.....	35
BDT014.....	52	DS019.....	120	KBDT029-04.....	36
BDT015.....	53	DS020.....	98	KBDT029-EASY20T.....	35
BDT017.....	53	DS022.....	101	KBDT029-EASY30T.....	36
BDT017-20.....	53	DS024.....	102	KCLQ005-00.....	17
BDT017-25.....	53	DS025.....	118	KCLQ005-00M.....	17
BDT017-40.....	54	DS100.....	98	KCLT003-00.....	15
BDT020.....	51	DSC012.....	103-120	KCLT003-00M.....	15
BDT027.....	51	DV001.....	132	KCLT007-00M.....	9
BDT029.....	56	DV002.....	133	KCLT007-00T.....	9
CAN001.....	130	DV003.....	134	KCLT007-01T.....	23
CAN001-CRSA.....	131	DV004.....	134	KCLT018-01.....	11
CAN002.....	130	DV005.....	135	KCLT018-02.....	13
CAN004.....	130	DV011.....	133	KCLT018-MIX00.....	11
CAN005.....	131	DV012.....	133	KCLT018-MIX02.....	13
CAN006.....	130	DV013.....	132	KCLT030-001.....	22
CAN007.....	131	DV014.....	132	KDC010.....	70
CAN008.....	131	DV020.....	135	KDC011.....	69
CLQ004-00.....	16	DV021.....	134	KDC040.....	71
CLQ005-00.....	17	DV026.....	134	KDC042.....	71
CLT001-00.....	14	FI005.....	141	KDC044.....	71
CLT003-00.....	15	FI006.....	141	KDC045.....	117
CLT007-00.....	9	FI011.....	153	KDI001.....	104
CLT008.....	8	FIE002.....	140	KDI001-01.....	105
CLT015-00.....	19	FIE003.....	140	KDI001-02.....	105
CLT015-03.....	18	FIE004.....	141	KDI001-ABS.....	104
CLT016-00.....	10	FIL001.....	140	KDPL001.....	70
CLT016-02.....	12	FIL002.....	140	KDPL001.....	70
CLT017-00.....	11	FIL003.....	140	KDS001.....	92
CLT029-00.....	20	FIL004.....	140	KDS002.....	92
CLT029-25-00.....	21	FLO01BIN.....	122	KDS003.....	93
CLT032.....	7	FLO01GIN.....	123	KDS004.....	93
CONF031.....	115	FLO01NEN.....	122	KDS005.....	94
CONF032.....	115	FLO08BI.....	125	KDS006.....	94
CONF033.....	115	FLO08NE.....	125	KDS007.....	97
CONF034.....	116	FLO08SI.....	126	KDS008.....	95
CONF035.....	115	FLO09SI.....	125	KDS009.....	97
CT002.....	137	FL013N.....	124	KDS011.....	94
CT002-01.....	137	FL015N.....	124	KDS012.....	96
CT005.....	137	FL019.....	127	KDS018.....	93
CT005-01.....	137	FL020.....	127	KDS022.....	95
CT006.....	137	FL021.....	127	KDS024.....	96
CT007.....	137	FL022.....	128	KDS100.....	92
DC004.....	74	FL027.....	126	KDS100-90.....	117
DC005.....	73	FL028.....	126	KDS100-91.....	117
DC006.....	74	FL032BIN.....	122	KDSC012.....	96

COD.	P.	COD.	P.	COD.	P.
KFL010.....	95	ROM002.....	147	SPAT004-01.....	108
KSLR002-04.....	63	ROM003.....	147	SPAT005.....	108
KSLT001-90-02.....	64	ROM004.....	147	SPAT005-01.....	109
KSPAQ001.....	72	ROM005.....	147	SPAT005-02.....	109
KSPAQ001-01OTTONE.....	72	ROM006.....	148	SPAT006.....	109
KSPAQ004.....	72	ROM007.....	148	SPAT007.....	111
KSPAQ004-ABS.....	72	ROM008.....	148	SPQ001.....	116
KSPAQ009.....	91	ROM009.....	147	SPQ002.....	116
KSPAQ009-01.....	105	ROM010.....	147	SPQ003.....	115
KSPAT002.....	72	SCAR001.....	139	SPT001.....	114
KSPAT002-01OTTONE.....	72	SCAR002.....	139	SPT001-01.....	114
KSPAT003.....	91	SETI03.....	44	SPT002.....	114
KSPAT003-04.....	104	SETI10.....	44	SPT004.....	114
KSPAT006-01.....	91	SFE002.....	58	SPT004-01.....	114
KSPAT007.....	72	SFQ001.....	45	SSEI03.....	48
KSPAT007-ABS.....	72	SFQ002.....	45	SSEI05.....	48
KSPE001.....	71	SFQ005.....	58	SSQ110.....	47
KSPQ001.....	70	SFQ104.....	45	SSQ111.....	47
KSPQ002.....	70	SFQ109.....	45	SSQ112.....	48
KSPQ002-ABS.....	70	SFT002.....	43	SSQ115.....	48
KSPT001-01.....	69	SFT004.....	43	SSR103.....	49
KSPT001-01ABS.....	69	SFT006.....	50	SSR105.....	49
KSPT002.....	69	SFT009.....	58	SST010.....	30
KSPT004.....	69	SFT022.....	49	SST020.....	31
KSPT004-ABS.....	69	SFT023.....	49	SST030.....	31
LIP04DN15.....	142	SFT029.....	50	SST110.....	46
LIP06DN15.....	142	SFT030.....	50	SST111.....	46
LIP08DN15.....	142	SFT103.....	43	SST112.....	47
LIPRI0DN15.....	142	SFT109.....	43	SST115.....	47
LIPRI2DN15.....	142	SIFQ001.....	139	SSX166.....	29
ORT100—ORT100-3/4.....	77	SIFT001.....	139	SSX168.....	30
ORT110—ORT110-3/4.....	77	SKQ009.....	46	SSX169.....	30
ORT120—ORT120-3/4.....	77	SKQ010.....	46	SSZ166.....	29
ORT121—ORT121-3/4.....	77	SKQ075.....	28	SSZ168.....	29
PAE001.....	113	SKQ170.....	27	SSZ169.....	30
PAQ001.....	113	SKQ172.....	28	TAP001.....	138
PAQ005.....	113	SKT009.....	44	TEQ001.....	81
PAT001.....	112	SKT010.....	44	TEQ002.....	82
PAT002.....	112	SKT075.....	27	TEQ003.....	81
PAT003.....	112	SKT170.....	27	TEQ004.....	82
PAT004.....	112	SKT172.....	27	TEQ005.....	81
PAT005.....	113	SLQ001-05REG.....	59	TEQ006.....	82
PEL100—PEL100-3/4.....	78	SLQ001-90REG.....	65	TEQ007.....	81
PEL110—PEL110-3/4.....	78	SLR002.....	65	TEQ010.....	82
PEL111—PEL111-3/4.....	78	SLR002-04.....	59	TET001-01.....	83
PEL120—PEL120-3/4.....	78	SLT001.....	66	TET002.....	84
PEL121—PEL121-3/4.....	78	SLT001-110-01.....	60	TET003-01.....	83
PEL130—PEL130-3/4.....	78	SLT001-110-02.....	61	TET004.....	85
PRO51.....	90	SLT001-110R.....	66	TET005-01.....	83
PRO51-INT15.....	90	SLT001-60-01.....	60	TET006.....	84
PRO52.....	90	SLT001-60-02.....	61	TET007-01.....	83
PRO52-INT15.....	90	SLT001-60R.....	66	TET010.....	84
PRO53.....	89	SLT001-90-01.....	60	TNQ003.....	86
PRO53-INT15.....	89	SLT001-90-02.....	61	TNQ005.....	86
PRO54.....	89	SLT001-90R.....	66	TNQ007.....	86
PRO54-INT15.....	89	SLT001-ASTA62.....	66	TNT001.....	85
PRO55.....	88	SLT001-ASTA90.....	66	TNT002.....	85
PRO55-INT15.....	88	SLT003-11.....	62	TNT003.....	87
PRO55-KIT10.....	88	SLT004.....	68	TNT005.....	87
PRO55-KIT15.....	88	SLT004-12.....	61	TNT007.....	86
PRO56-KIT10.....	87	SLT005-09.....	62	TO417.....	121
PRO56-KIT15.....	87	SLT013-REGOLABILE.....	68	TO438CRA-C/RACCORDINO.....	101
PRS100—PRS100-3/4.....	79	SLT014-05.....	63	TO712.....	121
RC005.....	149	SLT019.....	67	TRN110—TRN110-3/4.....	79
RC006-LIMI 6-8-10-12.....	149	SLT019-03.....	60	TRN111—TRN111-3/4.....	80
RC007-LIMI 6-8-10-12.....	149	SLT019R.....	67	TRN112—TRN112-3/4.....	80
RC008-LIMI 6-8.....	151	SN011.....	136	TRQ001.....	38
RC009.....	151	SN012.....	136	TRQ002.....	40
RC010.....	151	SNA011.....	136	TRQ003.....	41
RC011.....	151	SNA012.....	136	TRQ004.....	41
RC012.....	150	SPAQ001.....	111	TRT001.....	38
RC013.....	150	SPAQ002.....	110	TRT002.....	38
RC014.....	151	SPAQ003.....	110	TRT003.....	38
RC015.....	150	SPAQ004.....	111	TRT004.....	40
RC016.....	150	SPAT001.....	110	VNR001.....	152
RC017.....	150	SPAT001-03.....	110	VNR003.....	152
RC018.....	149	SPAT002.....	111	VNR005.....	152
RC019.....	149	SPAT003.....	107		
RC022.....	150	SPAT003-01.....	107		
RO015.....	138	SPAT003-02.....	107		
RO017.....	138	SPAT004.....	108		

Condizioni generali di vendita

Le presenti condizioni generali disciplinano tutti gli attuali e futuri contratti fra le parti, salvo eventuali deroghe specificatamente concordate per iscritto. Eventuali condizioni generali del compratore non troveranno applicazione nei rapporti futuri tra le parti se non espressamente accettate per iscritto dalla ditta Nuova Osmo.

1. Formazione del contratto

L'invio da parte del compratore di un ordine al venditore comporta l'applicazione al contratto di vendita delle presenti condizioni generali. Il venditore si riserva il diritto di accettare o rifiutare l'ordine ricevuto. Le offerte fatte da agenti, rappresentanti ed ausiliari di commercio del venditore non sono per lui impegnative fino a quando non siano confermate dal venditore stesso.

2. Prezzi

Ai prezzi indicati nel presente listino deve essere applicata l'I.V.A. secondo l'aliquota in vigore al momento della fatturazione. Il venditore si riserva di modificare i prezzi, o variare il listino prezzi senza alcun preavviso.

3. Resa della Merce

Salvo patto contrario, la fornitura dei prodotti si intende Franco Fabbrica del venditore: trasporto ed assicurazione sono pertanto a carico del compratore e ciò anche quando sia convenuto che la spedizione o parte di essa venga curata dal venditore, nel qual caso quest'ultimo agirà come mandatario del compratore, essendo inteso che il trasporto verrà effettuato a rischio del compratore.

I rischi relativi alla fornitura passano al compratore al momento in cui i prodotti lasciano lo stabilimento del venditore.

4. Termini di consegna

I termini di consegna si intendono approssimativi a favore del venditore e comunque con un congruo margine di tolleranza.

È esclusa qualsiasi responsabilità del venditore per danni derivanti da anticipata, ritardata o mancata consegna, totale o parziale.

Il compratore è sempre tenuto a prendere in consegna i prodotti, anche in caso di consegne parziali e quando i prodotti vengano consegnati prima o successivamente alla data di consegna stabilita. Il termine di consegna verrà prorogato di un periodo pari a quello della durata dell'impedimento al verificarsi di cause di forza maggiore. In nessun caso, a causa del verificarsi di tali circostanze, il compratore potrà esigere compensi o indennizzi di qualsiasi natura.

5. Garanzia

Il venditore garantisce la conformità dei prodotti forniti; con il termine di conformità dei prodotti si intende che essi corrispondono per qualità, quantità e tipo a quanto stabilito nel contratto e che sono esenti da vizi che potrebbero renderli non idonei all'uso cui sono destinati. La garanzia per vizi è limitata ai soli difetti dei prodotti conseguenti a difetti di progettazione, di materiale o di costruzione riconducibili al venditore e non si applica nel caso in cui il compratore non provi di aver effettuato una corretta conservazione dei prodotti e di non averli modificati senza il consenso del venditore. Il venditore non risponde dei difetti di conformità dei prodotti dovuti all'usura normale di quelle parti che, per loro natura sono soggette a usura rapida e continua.

6. Reclami

Il compratore è tenuto a verificare la conformità dei prodotti e l'assenza di vizi. I reclami relativi a non conformità dei prodotti forniti dovranno essere effettuati, a pena di decadenza, entro e non oltre quindici giorni dal ricevimento della merce a destino. I vizi, difetti o non conformità occulti devono essere denunciati immediatamente alla loro scoperta e comunque, a pena di decadenza, entro e non oltre sei mesi dalla data di consegna. Tutti i reclami devono essere effettuati mediante lettera raccomandata indirizzata al venditore e devono indicare dettagliatamente i vizi e le non conformità contestate. La garanzia ha una durata di sei mesi.

7. Rimedi

In caso di prodotti non conformi, e dopo aver ricevuto un rapporto dettagliato dal compratore, il venditore potrà, a sua insindacabile scelta:

- a) fornire gratuitamente Franco Fabbrica al compratore prodotti dello stesso genere e quantità di quelli risultanti difettosi o non conformi a quanto pattuito, dopo averne ottenuto la resa per la verifica. L'eventuale sostituzione effettuata prontamente dal venditore non può essere ritenuta un implicito riconoscimento dei vizi contestati: detto riconoscimento dovrà essere sempre esplicito e conseguente al controllo del venditore sui prodotti contestati. Qualora il venditore, in sede di verifica, non riconosca viziati i prodotti, provvederà alla fatturazione di quelli inviati in sostituzione.
- b) emettere una nota di accredito a favore del compratore per un importo corrispondente al valore dei prodotti difettosi.

In entrambi i casi il venditore ha diritto alla restituzione dei prodotti difettosi, che diventano di sua proprietà.

8. Limitazione di responsabilità del venditore

Salvo dolo o colpa grave del venditore, l'eventuale risarcimento di qualsiasi danno al compratore non potrà comunque superare il prezzo di fattura dei prodotti contestati.

9. Pagamento

I pagamenti ed ogni altra somma dovuta a qualsiasi titolo al venditore si intendono netti al suo domicilio. Qualsiasi ritardo o irregolarità nel pagamento dà al venditore il diritto di sospendere le forniture o di risolvere contratti in corso, anche non relativi ai pagamenti in questione, nonché il diritto al risarcimento degli eventuali danni. Il venditore ha altresì il diritto a decorrere dalla scadenza del pagamento, agli interessi moratori nella misura stabilita in Italia dall'articolo 5 del Decreto Legislativo 9 Ottobre 2002, n° 231. Il ritardo nei pagamenti dà altresì al venditore il diritto di escludere la garanzia per tutto il periodo durante il quale il ritardo perdura.

10. Riserva di proprietà

I prodotti consegnati restano di proprietà del venditore sino al momento del completo pagamento del prezzo.

11. Legge applicabile e foro competente

Tutti i contratti disciplinati dalle presenti condizioni generali sono regolati dalla legge italiana.

Per ogni controversia relativa o comunque collegata ai contratti cui si applicano le presenti condizioni generali è esclusivamente competente il foro del venditore: quest'ultimo avrà tuttavia facoltà di agire presso il foro del compratore.

General conditions for sale

These general conditions regulate all present and future sales contracts between the parties, subject to any exceptions specifically agreed upon in writing. Any general conditions of the purchaser will not apply to future contractual relations between the parties unless expressly accepted in writing by Nuova Osmo.

1. Formation of the Contract

The purchaser placing the order fully accepts the application of these general terms to the contract for sale. Seller reserves the right to accept or refuse it. Offers made by Agents, Representatives or auxiliaries of the seller do not bind him until they are confirmed by the seller itself.

2. Prices

The prices indicated in this price list do not include V.A.T. or any other tax whatsoever. Seller may modify the prices / price list without prior notice.

3. Surrender of the goods

Unless agreed to the contrary, the supply of the products is intended ex-factory; transport and insurance are therefore at the charge of the purchaser, this also when it is decided that the delivery or part of it will be taken care of by the seller, in which case the latter will act as the purchaser's agent, it being understood that the transport will be carried out at the expense and risk of the purchaser. The risk relative to the supply pass to the purchaser, at the latest at the time in which the products leave the seller's plant.

4. Delivery terms

The delivery limits are agreed approximately in favour of the seller and not binding for him. Any liability of the seller is excluded for damage deriving from anticipated, delayed or non delivery, total or partial.

The purchaser is always held to take delivery of the products, even in the case of partial deliveries and even when the products are consigned before the established delivery date of successively to that date.

The seller shall not be deemed to be in breach of this agreement, or otherwise be liable to the purchaser, by reason of any delay in delivery, to the extent that the delay is due to any Force Major, and the time for performance of delivery shall be extended accordingly.

5. Guarantee

The seller guarantees the compliance of the products supplied; by the term compliance of the products it is meant that they correspond in quality, quantity and type to what was agreed in the contract and that they are without defects that could render them unfit for the use to which they are intended to be put. The guarantee against defects is limited only to product defects due to defects in planning, materials or construction that can be attributed to the seller, and does not apply in the case where the purchaser is unable to prove a correct preservation of the product and where he has modified them without the agreement of the seller. The seller is not liable for defects in product compliance due to the normal wear of those parts which, by nature, are subject to rapid and continuous wear and tear.

6. Claims

The purchaser is required to control the compliance of the products and the absence of flaws.

Claims relevant to non-conformities of the goods must be made, on pain of forfeiture, within and not later than fifteen days from the goods arrival at their place of destination.

Hidden flaws, defect or non-compliances must be reported immediately after the discovery and in any event, on pain of forfeiture, not later than six months from the delivery date.

Claims must be made by registered letter, addressed to the seller and must describe in detail the flaws or disputed non-compliances. The guarantee is for a limited period of six months from delivery date.

7. Remedies

In case of faulty products and following to a report by the purchaser, the seller may at his discretion:

- a) supply ex-factory to the purchaser products of the same kind and quantity as those that proved not in compliance, on receiving returns for checking. Any replacement carried out promptly by the seller cannot be considered as implicit recognition of defects claimed: said recognition must always be explicit and following control by seller on goods challenged: should the seller, on controlling, find the goods in compliance, he will invoice for those sent in replacement;
- b) issue to the purchaser a credit-note in the amount equal to the value of the defective products.

In both cases the purchaser shall return the faulty products to the seller.

8. Limit of the seller's liability

Except in the case of fraud or gross negligence on the seller's part, compensation of any damage to the purchaser will not, in any event, be greater than invoice price of the disputed products.

9. Payments

The payment and every other sum due to the seller, are understood as net at the registered office of the seller.

Any delay or irregularity in the payment gives the seller the right to suspend the supply or to cancel the contract in course, even if they are not relevant to the payment in question, as well as the right to the compensation for eventual damages. The seller has also the right – starting from the payment deadline – to interests for delay as per art. 5 of Italian Legislative Decree no. 231 of 09/10/2002. The delays of payment likewise give the seller the right to exclusion from guarantee, for the whole period that the delay may persist.

10. Retention of Title

The delivered products remain the seller's property until the moment of the complete payment of the price.

11. Applicable Law and Competent Law-Court

All contracts ruled by these general conditions are submitted to Italian Law. For any controversy relative to, connected to the contractual products to which these general conditions apply, the seller's Law-Court has the exclusive competence: the latter, however, will have the opportunity to act also in the purchaser's Law-Court.

Conditions générales de vente.

Les présentes conditions générales disciplinent tous les contrats actuels et futurs entre les parties, sous réserve des exceptions convenues par écrit. Toutes les éventuelles conditions générales de l'acheteur ne trouveront pas d'application dans les relations futures entre les parties si non expressément acceptées par écrit par la société Nuova Osmo.

1. Formation du contrat

L'envoi par l'acheteur au vendeur d'une commande entraîne l'application au contrat de vente des présentes conditions générales. Le vendeur se réserve le droit d'accepter ou de refuser l'ordre reçu. Les offres faites par les agents, représentants et intermédiaires commerciaux du vendeur ne contraignent le vendeur que dès lors qu'elles sont confirmées par le vendeur lui-même.

2. Prix

Aux prix indiqués dans cette liste de prix doit être appliquée l'I.V.A au taux en vigueur au moment de la facturation. Le vendeur se réserve le droit de modifier les prix, ou de modifier la liste de prix sans aucun préavis.

3. Marchandise rendue

Sauf si contrairement convenu, la fourniture des produits s'entend départ usine du vendeur: transport et assurance sont pour autant à la charge de l'acheteur et ceci même lorsqu'il est convenu que l'expédition du lot ou d'une partie de celui-ci est préparée par le vendeur, dans ce cas, ce dernier agira comme représentant de l'acheteur, entendu que le transport sera effectué au risque de l'acheteur. Les risques relatifs à la fourniture passent à l'acheteur dès que la marchandise quitte l'usine du vendeur.

4. Termes de livraison

Les délais de livraison s'entendent approximatifs en faveur du vendeur et en tout cas avec une marge de tolérance raisonnable. Toute responsabilité du vendeur est exclue pour dommages dérivant de livraison anticipée, retardée ou manquée de façon totale ou partielle. L'acheteur est toujours tenu à prendre les produits livrés, même en cas de livraisons partielles et lorsque les marchandises sont livrées avant ou après la date de livraison prévue. La date de livraison sera prolongée d'une période égale à la durée de l'empêchement à l'apparition de causes de force majeure. En aucun cas, à cause de survenance de telles circonstances, l'acheteur ne pourra prétendre à indemnisation ou remboursement de quelque nature.

5. Garantie

Le vendeur garantit la conformité des produits fournis; avec le terme conformité des produits il est entendu que ces produits correspondent en qualité, quantité et type à ce qui est établi dans le contrat et qu'ils sont exempts de défauts qui pourraient les rendre impropres à l'usage auquel ils sont destinés.

La garantie pour les défauts est limitée aux défauts des produits résultants de défauts de conception, de matériaux ou de fabrication imputables au vendeur, et n'est pas applicable dans le cas où l'acheteur ne prouve pas qu'il a correctement conservés les produits et qu'il ne les a pas modifiés sans le consentement du vendeur. Le vendeur ne répond pas des défauts de conformité des produits qui sont dus à l'usure normale des pièces qui, de par leur nature, sont soumises à une usure rapide et continue.

6. Plaintes

L'acheteur est tenu de vérifier la conformité des produits et l'absence de vices. Les plaintes relatives à non-conformité des produits fournis doivent être faites, sous peine de déchéance, au plus tard dans les quinze jours qui suivent de la réception à destination des marchandises. Les vices, défauts ou de non-conformité cachés doivent être signalés immédiatement à leur découverte et, en tout cas, sous peine de déchéance, au plus tard dans les six mois à compter de la date de livraison. Toutes les plaintes doivent être faites par lettre recommandée adressée au vendeur et doivent indiquer de façon détaillée les vices et les non-conformités contestés. La garantie a une durée de six mois.

7. Recours

En cas de produits non conformes, et après avoir reçu un rapport détaillé de l'acheteur, le vendeur peut, à sa seule discrétion:

- a) fournir gratuitement à l'acheteur en départ usine des produits de même nature et quantité que ceux résultants défectueux ou non conformes à ce qui avait été établi, après en avoir obtenu le rendement pour vérification. Tout éventuel remplacement effectué sans délai par le vendeur ne peut pas être considérée comme une reconnaissance implicite des défauts contestés: la dite reconnaissance devra toujours être explicite et conséquente au contrôle de la part du vendeur des produits contestés. Si le vendeur, après vérification, ne reconnaît pas de défaut qui lui soit imputable sur les produits, il facturera les produits envoyés en substitution;
- b) émettre une note de crédit en faveur de l'acheteur pour un montant correspondant à la valeur des produits défectueux. Dans les deux cas, le vendeur a le droit à la restitution des produits défectueux, qui deviennent de sa propriété.

8. Limitation de responsabilité du vendeur

Sauf intention ou faute grave du vendeur, l'éventuelle compensation de tout dommage à l'acheteur ne pourra en aucun cas dépasser le prix facturé des produits contestés.

9. Paiement

Les paiements et toute autre somme due à quelque titre que ce soit au vendeur, s'entendent nets à son domicile. Tout retard ou irrégularité dans le paiement donne au vendeur le droit de suspendre les livraisons ou de résilier les contrats en cours, même s'ils ne sont pas relatifs aux paiements en question, ainsi que le droit à l'indemnisation des dommages. Le vendeur a également droit, à partir de la date d'échéance du paiement, aux intérêts de retard dans la mesure établie à l'article 5 du décret législatif italien 9 Octobre 2002 n° 231. Le retard de paiement donne également au vendeur le droit d'exclure la garantie tout au long de la période durant laquelle le retard persiste.

10. Réserve de propriété

Les produits livrés restent sous la propriété du vendeur jusqu'à complet paiement du prix.

11. Loi applicable et juridiction

Tous les contrats disciplinés par ces conditions générales présentes sont régies par la loi italienne. Tout litige dérivant de, ou relié à des contrats auxquels s'appliquent ces conditions générales est sous la compétence exclusive de la juridiction du vendeur: ce dernier aura toutefois la faculté d'agir dans la juridiction de l'acheteur.



Nuova Osmo srl

Società unipersonale

Via Dr. Bellosta, 46

28017 San Maurizio d'Opaglio - (Novara) Italy

Tel. +39 0322 950 272

Fax. +39 0322 950 200

info@nuovaosmo.com

www.nuovaosmo.com